

Flow Distribution Influences on Air Pollution Control Equipment Performance

Robert Mudry, P.E.

Vice President – Engineering
Airflow Sciences Corporation
rmudry@airflowsciences.com

WPCA Seminar – Dominion Generation

October 24-25, 2005



Outline

- ❖ Introduction
- ❖ Flow Distribution Analysis Techniques
- ❖ Application to Air Pollution Control Equipment
 - ESP
 - FF
 - SCR
 - FGD
- ❖ Other Applications
- ❖ Conclusions
- ❖ Questions

Introduction

❖ Why is Flow Distribution Important to APC Equipment?

- Performance
 - Flow uniformity
 - Chemical species injection
 - Ash capture / build-up
- Operating costs
 - Pressure drop
 - Erosion
 - Corrosion

❖ Applications

- Design of new equipment
- Retrofit of existing equipment
- Solving operational or maintenance issues

Outline

- ❖ Introduction
- ❖ Flow Distribution Analysis Techniques
 - Field Testing
 - Computational Fluid Dynamics (CFD)
 - Physical Flow Modeling
- ❖ Application to APC Equipment
- ❖ Other Applications
- ❖ Conclusions
- ❖ Questions

Field Testing

- ❖ Velocity
- ❖ Temperature
- ❖ Pressure
- ❖ Particulate
- ❖ Chemical species

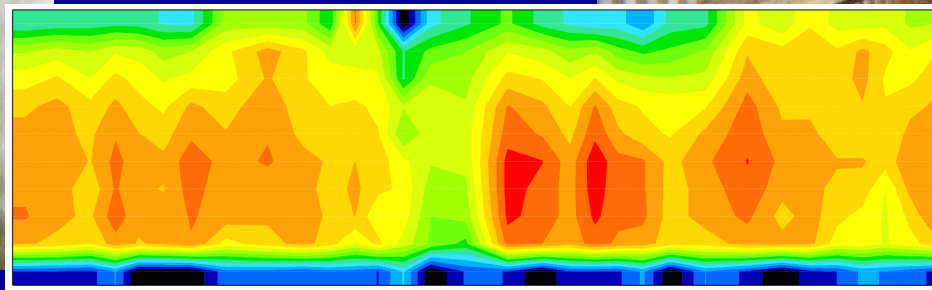

Physical Flow Modeling

❖ Pros

- Easy flow visualization
- Ash buildup analysis
- Touch & feel benefit
- Gas injection possible

❖ Cons

- “Cold” flow
- Geometric simplification
- Scaled (incl perforated plate)
- Longer schedule & more \$\$ than CFD model
- Harder to make design changes (serial)



Computational Fluid Dynamics (CFD) Modeling

❖ Pros

- Thermal effects considered
- Full scale
- Lower \$\$ and time than physical model
- Liquid & gas injection possible
- Easy to make changes
- Design runs done in parallel

❖ Cons

- Geometry is “virtual”
- Bulk effects of small geometry modeled
- Ash dropout & reentrainment prediction issues
- Require high-end computers

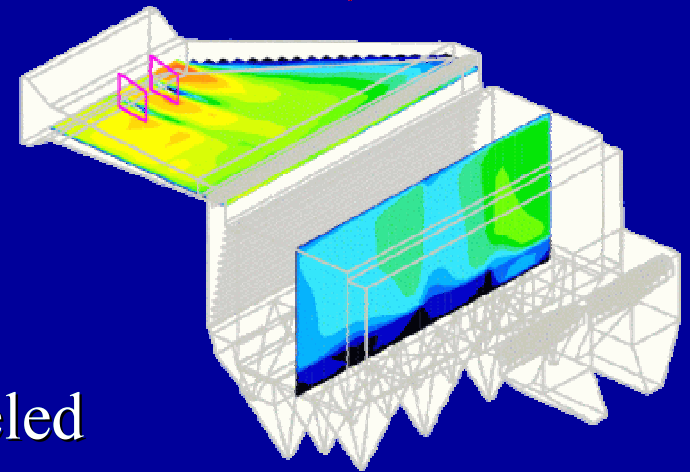
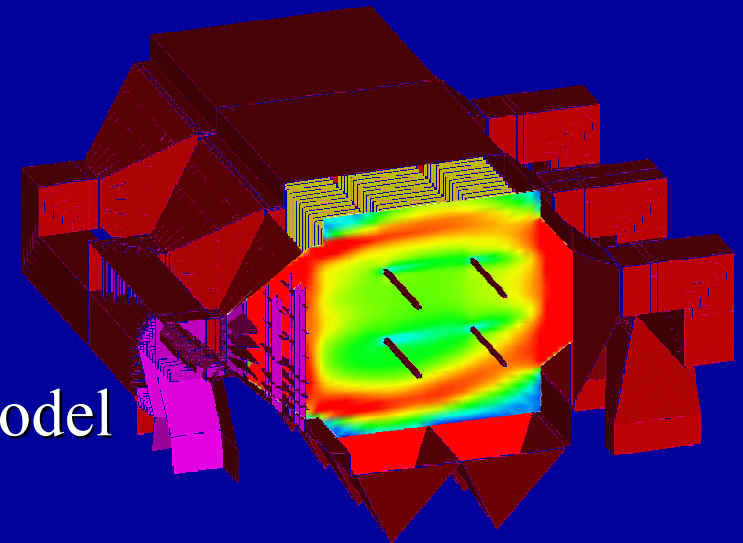

Outline

- ❖ Introduction
- ❖ Flow Distribution Analysis Techniques
- ❖ Application to APC Equipment
 - ESP
 - FF
 - SCR
 - FGD
- ❖ Other Applications
- ❖ Conclusions
- ❖ Questions

ESP Flow Modeling

- ❖ Flow distribution
- ❖ Flow balance between cells
- ❖ Pressure loss
- ❖ Thermal mixing
- ❖ Gas conditioning
- ❖ Ash deposition

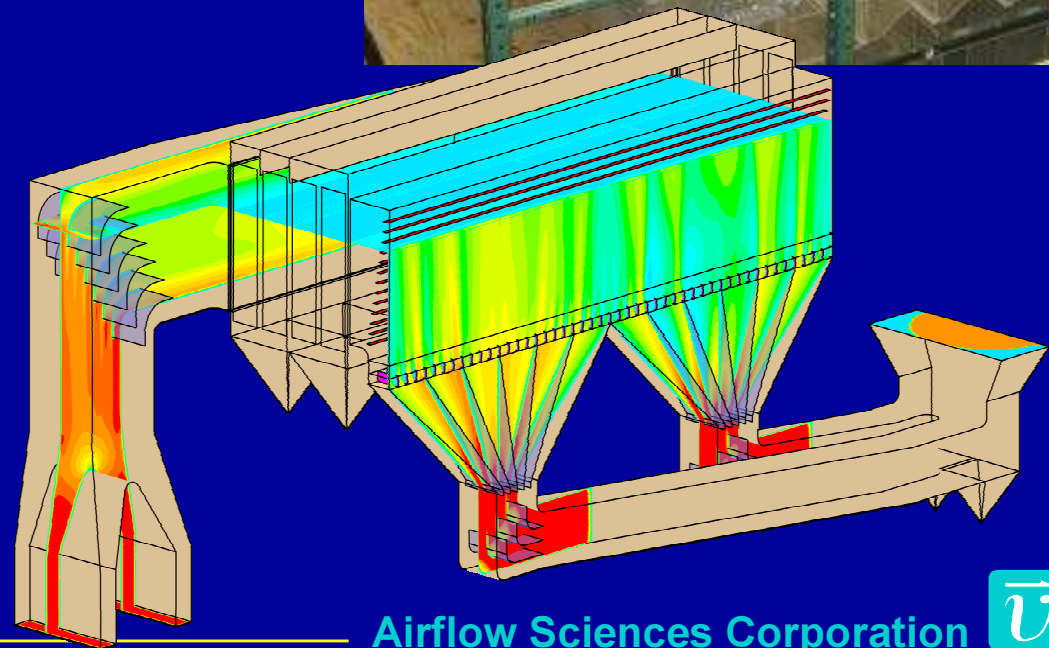

ESP Velocity Distribution

- ❖ Uniform velocity within collection region
- ❖ Industry standards

- ICAC
- % RMS deviation

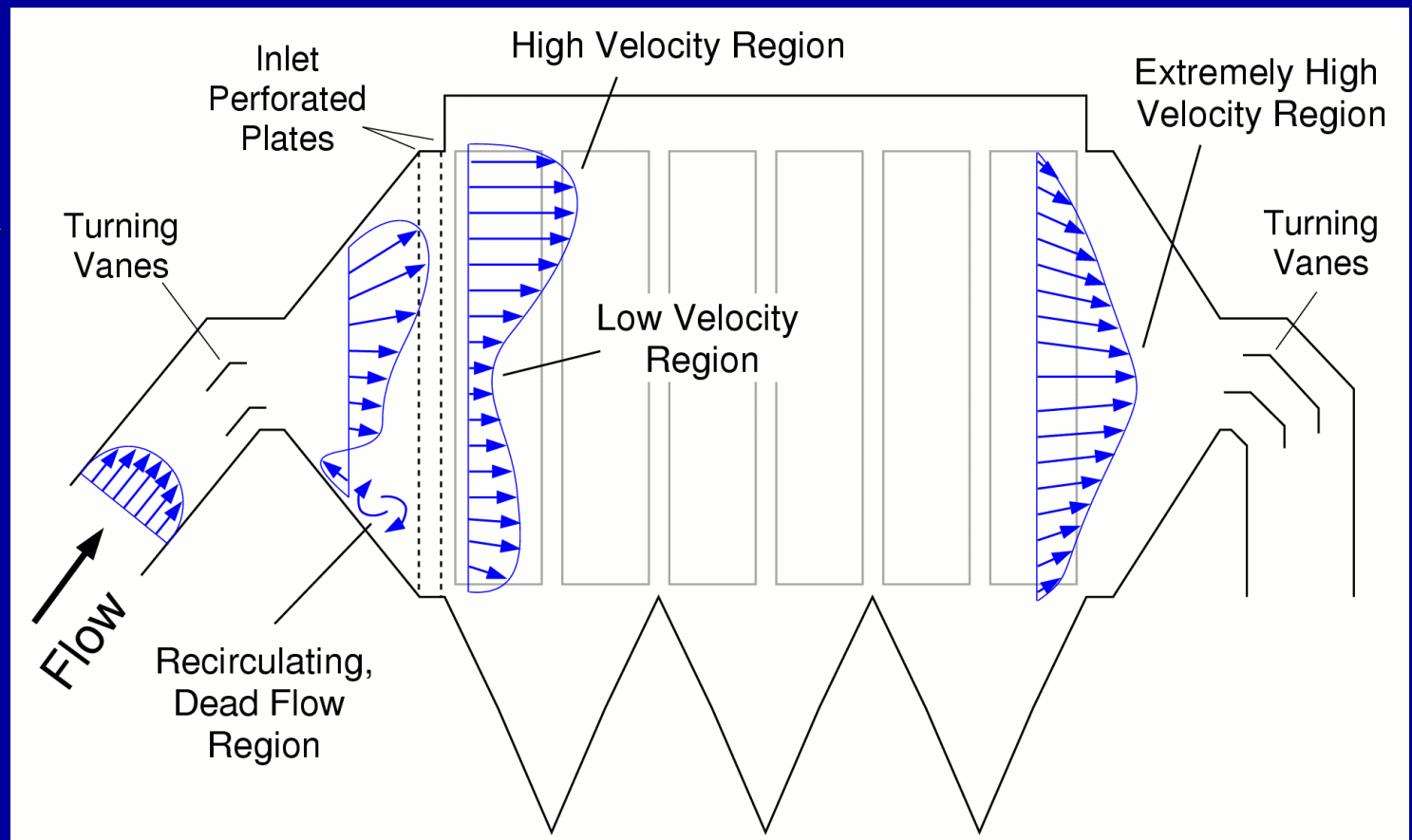

Gas Flow Balance

- ❖ Industry standard +/- 10% deviation

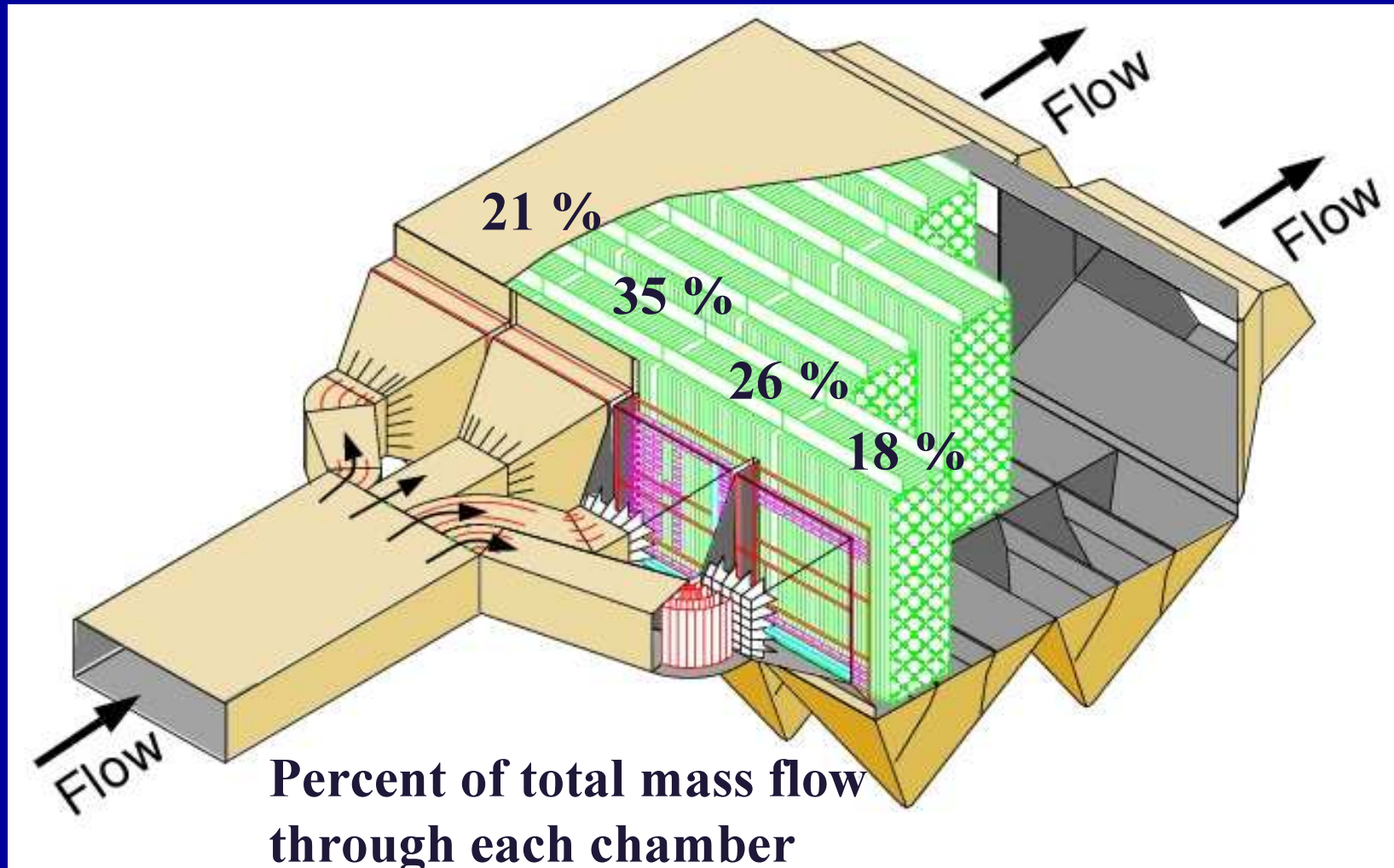

Pressure Drop

- ❖ General goal:
 - Minimize DP
- ❖ Methods
 - Vanes
 - Duct contouring
 - Area management

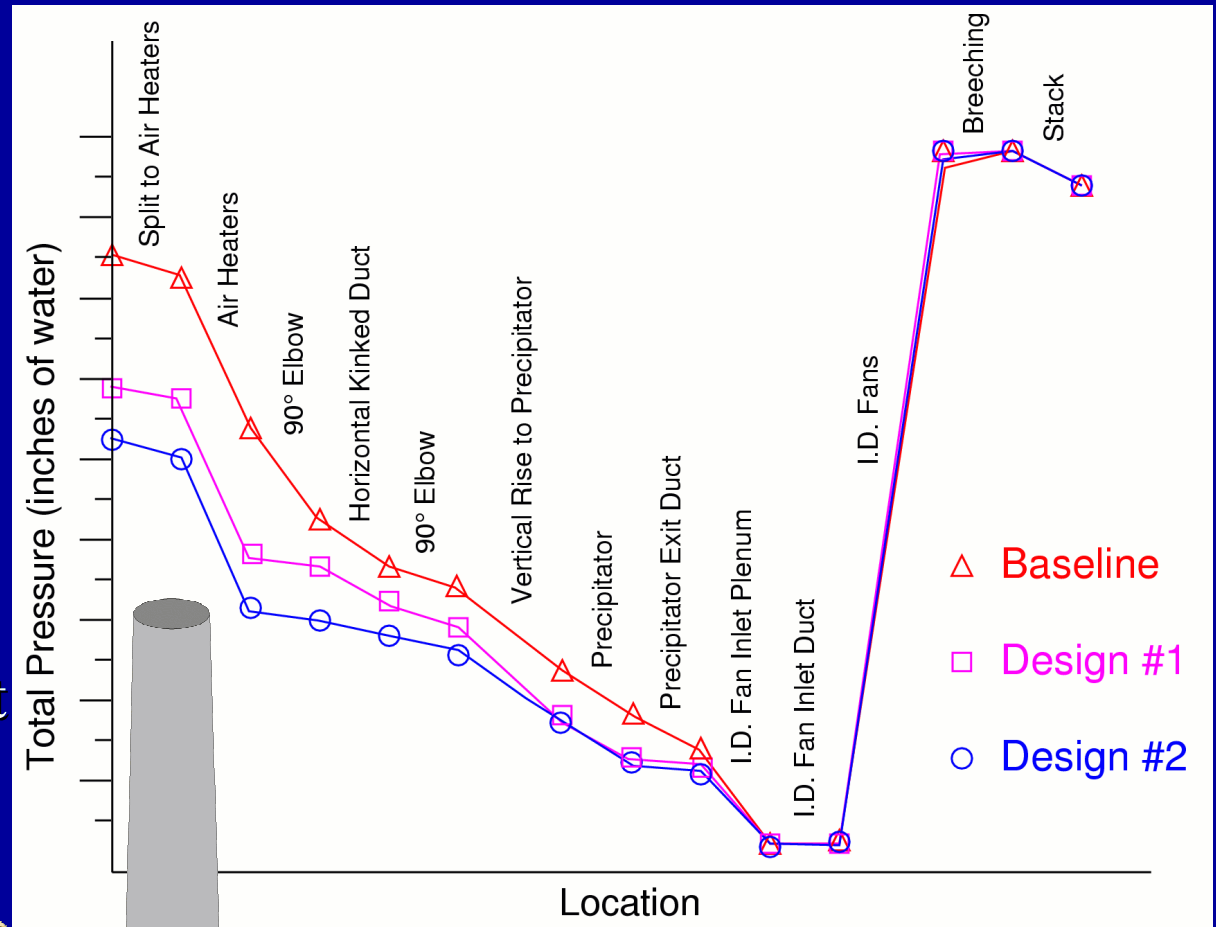
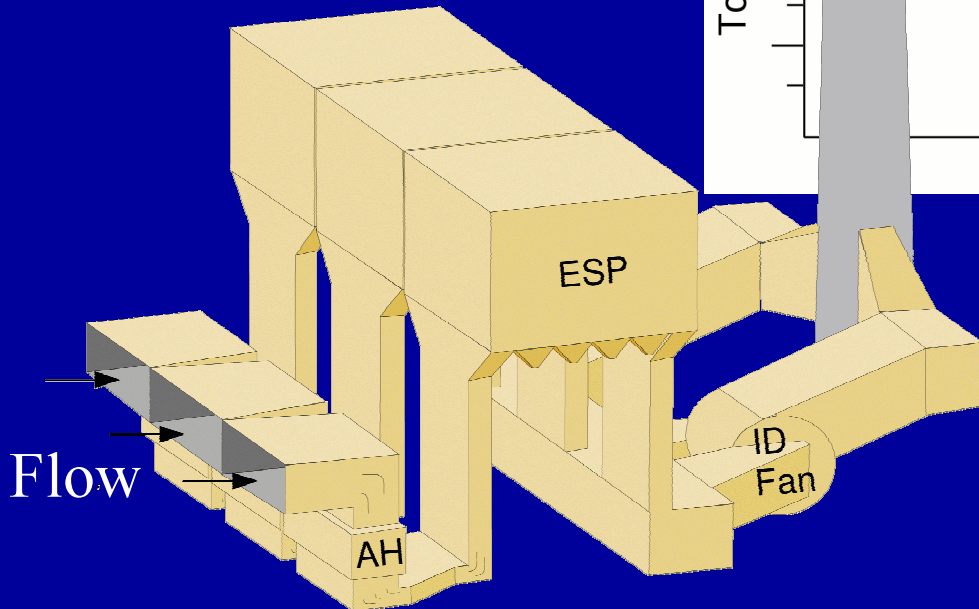

Ductwork redesign saves
2.1 inches H₂O over baseline



ESP Temperature Stratification

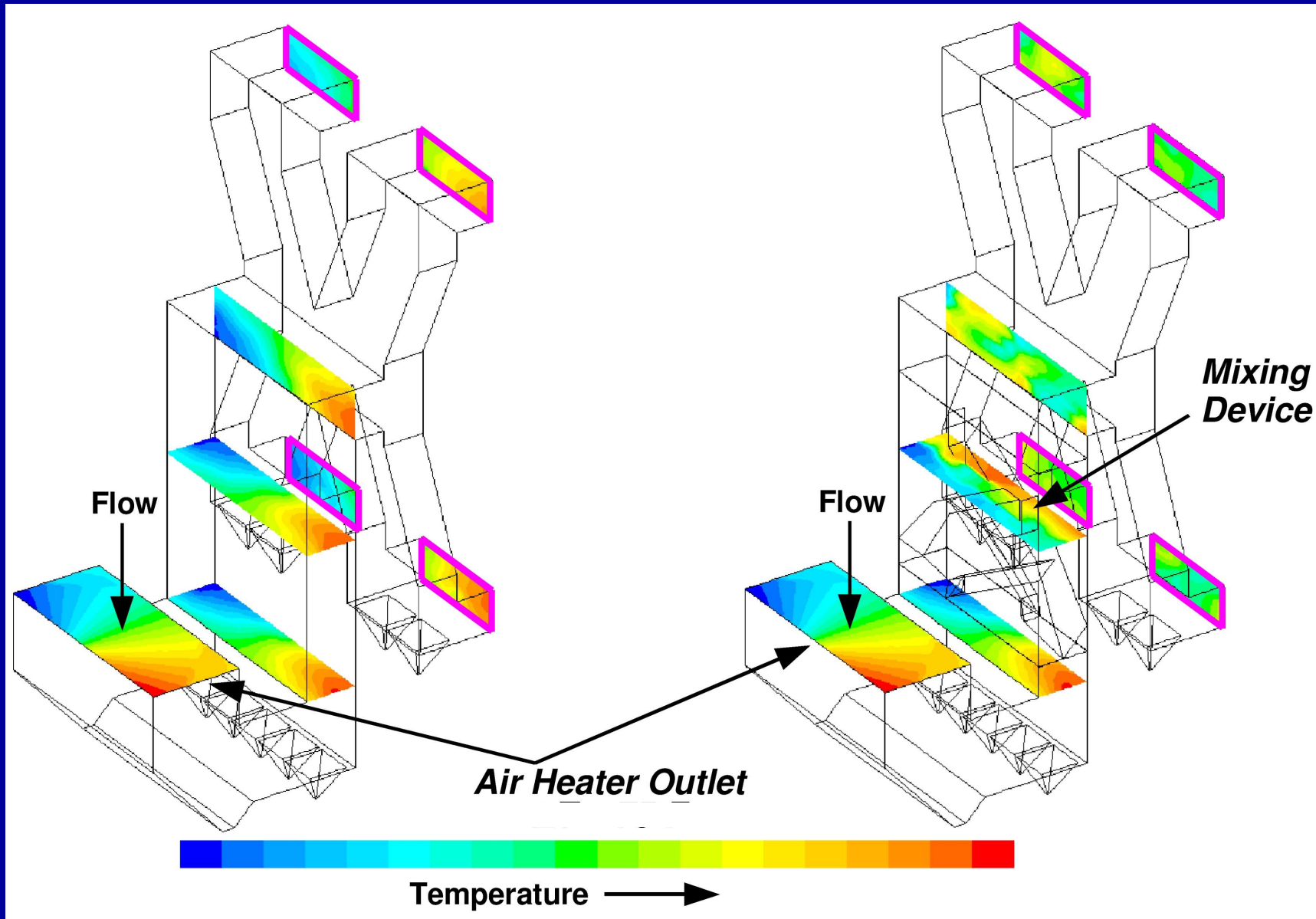

ESP Gas Conditioning

- ❖ Modify ash resistivity
 - SO_3 , ammonia, others
- ❖ Alter gas density, viscosity
 - Humidification

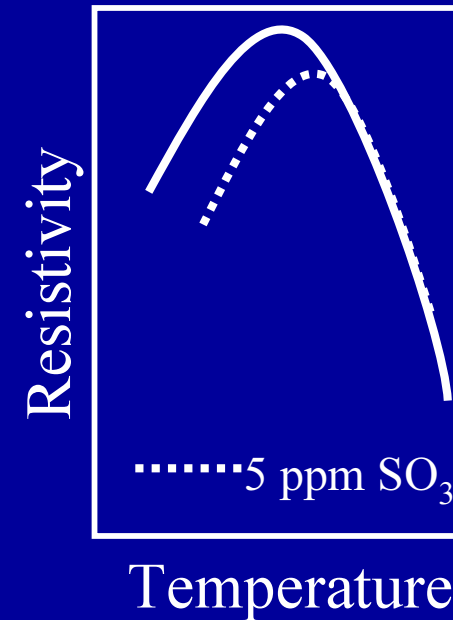

Humidification gone awry

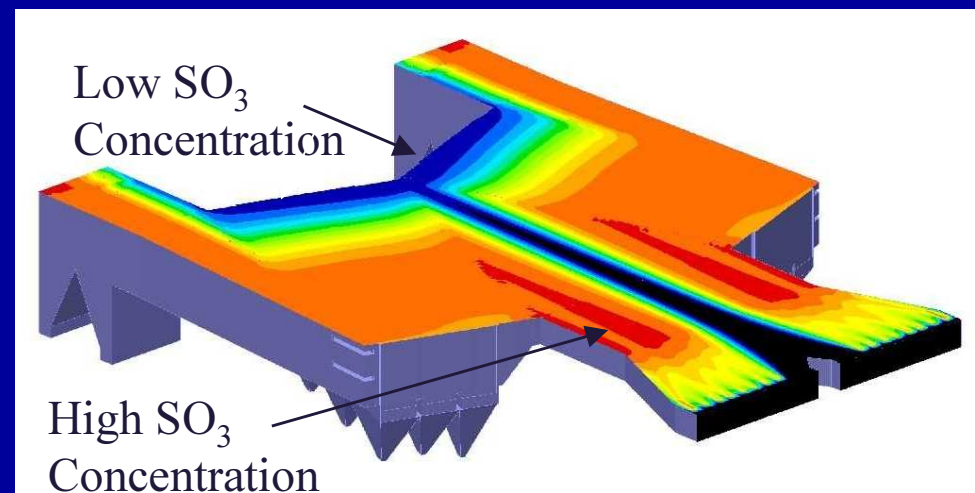

Ash Deposition

- ❖ Drop out
- ❖ Re-entrainment

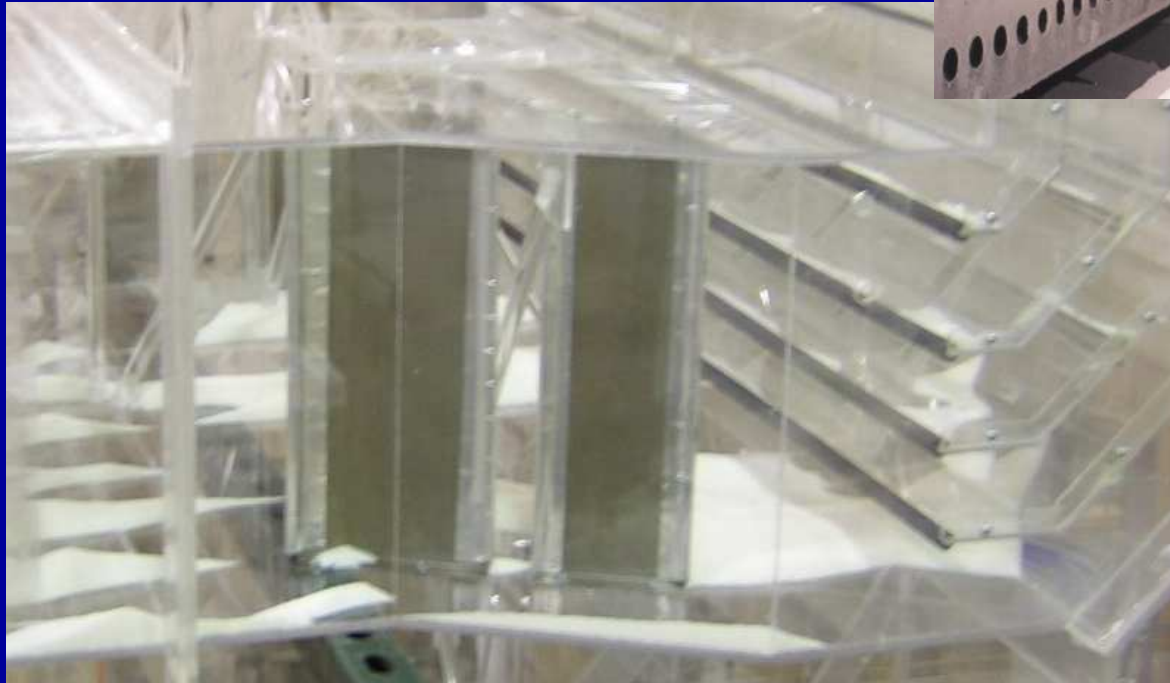

Fabric Filter Flow Modeling

- ❖ Flow distribution
- ❖ Flow balance between compartments
- ❖ Pressure loss
- ❖ Bag erosion
- ❖ Thermal mixing
- ❖ Ash deposition

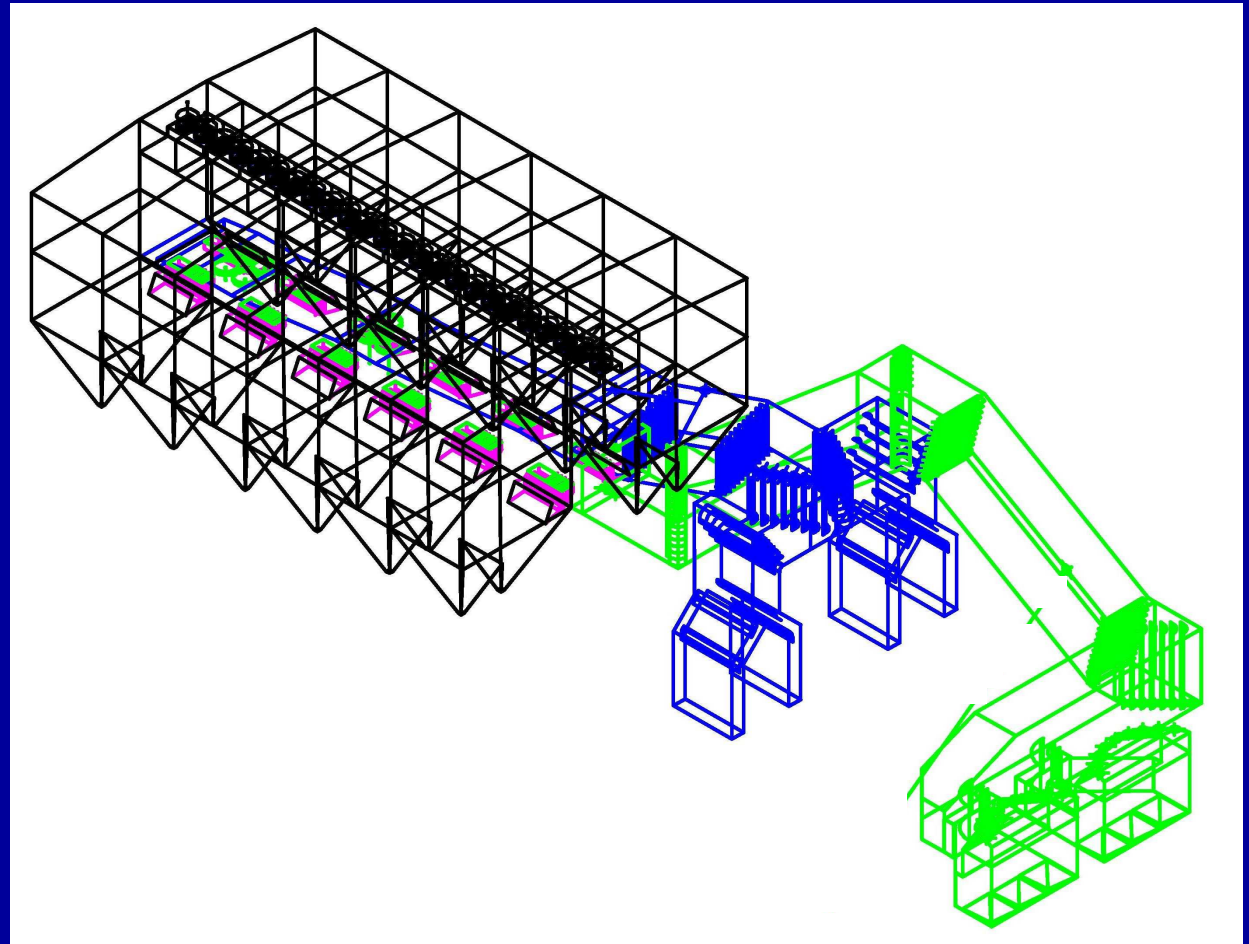

SCR Flow Modeling

- ❖ Flow distribution
- ❖ Thermal mixing
- ❖ NO_x profile / mixing
- ❖ Ammonia injection
- ❖ Pressure loss
- ❖ Large particle ash (LPA) or “popcorn ash” capture
- ❖ Ash deposition



SCR Flow Distribution

- ❖ Velocity profile
 - At AIG
 - At SCR inlet
 - At AH inlet
- ❖ Directionality
 - At SCR inlet



SCR Thermal Mixing

- ❖ SCR low load operation with economizer bypass
- ❖ CFD model to design mixer using full scale operating conditions
- ❖ Physical model tracer gas tests to confirm design

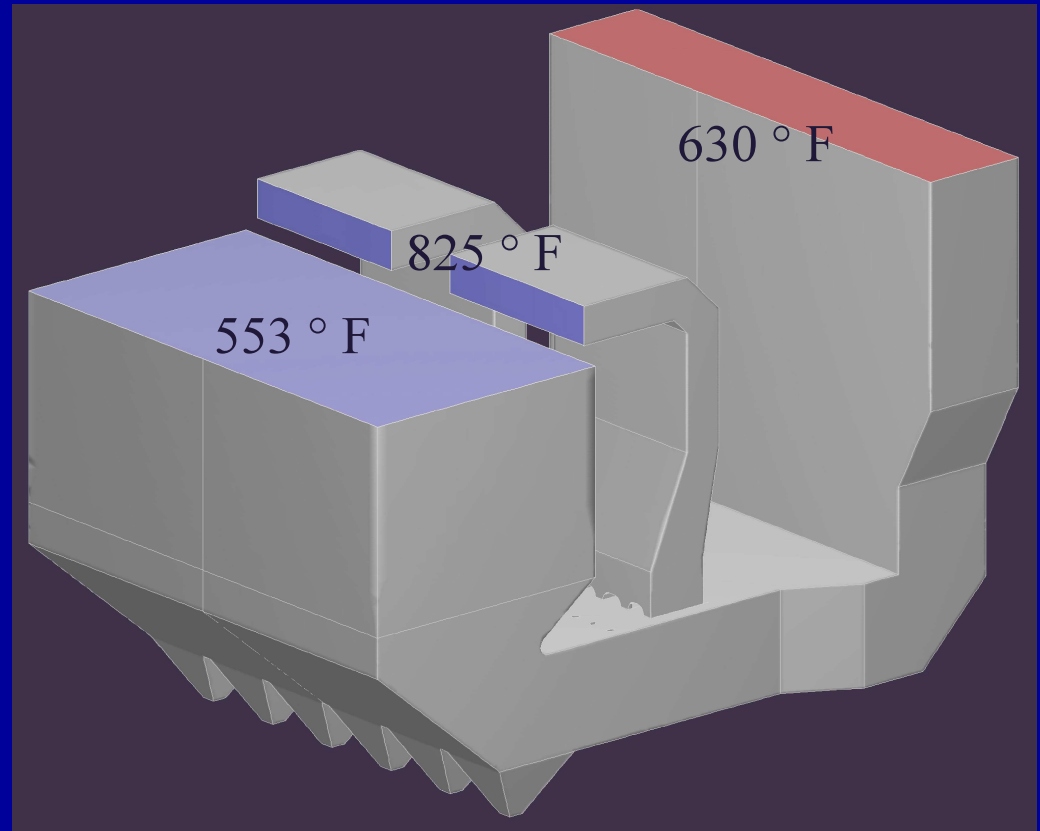

Without mixer, $\Delta T = \pm 83$ °F

With mixer, $\Delta T = \pm 15$ °F

SCR Ammonia Injection

- ❖ Tracer gas in physical model
- ❖ Species tracking in CFD

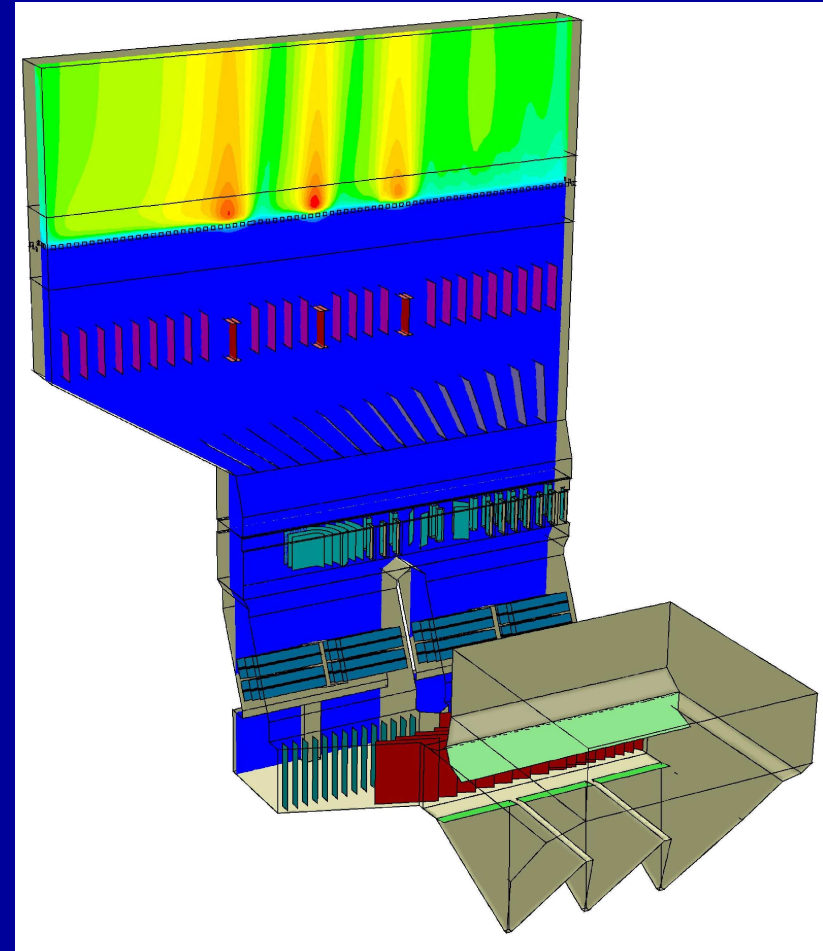

SCR Large Particle Ash Capture

- ❖ Complicated aerodynamic properties

- Light weight
- Unique drag coefficient
- Random rebound



- ❖ CFD modeling to predict:

- Gas velocity patterns
- LPA particle paths
- Hopper capture efficiency
- Pressure loss
- Erosion potential

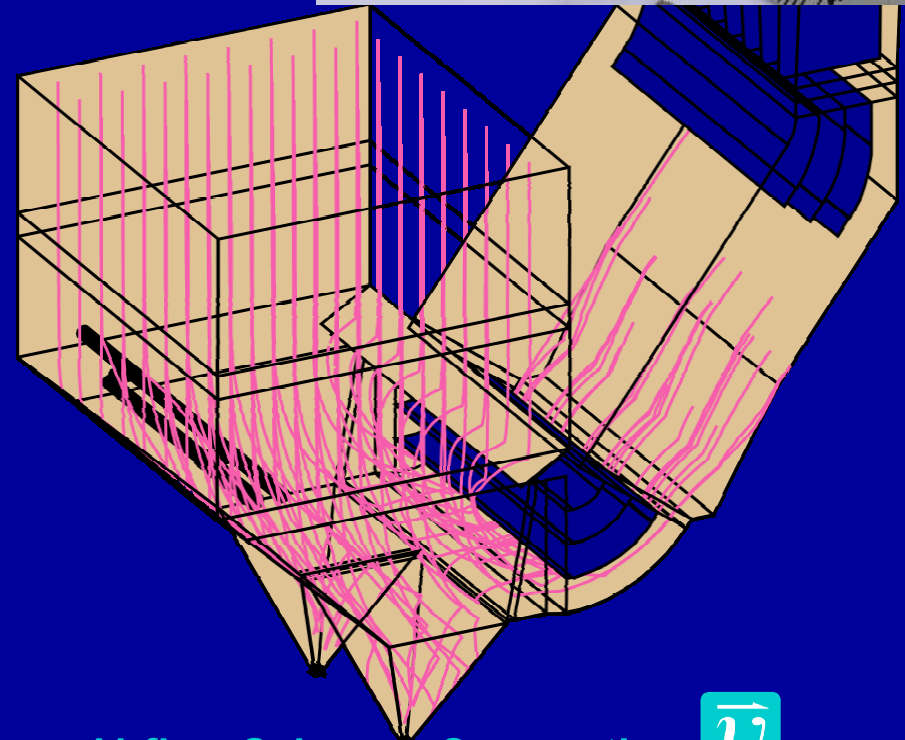

FGD Flow Modeling

- ❖ Flow distribution
- ❖ Water droplet behavior
- ❖ Pressure loss
- ❖ Ash deposition

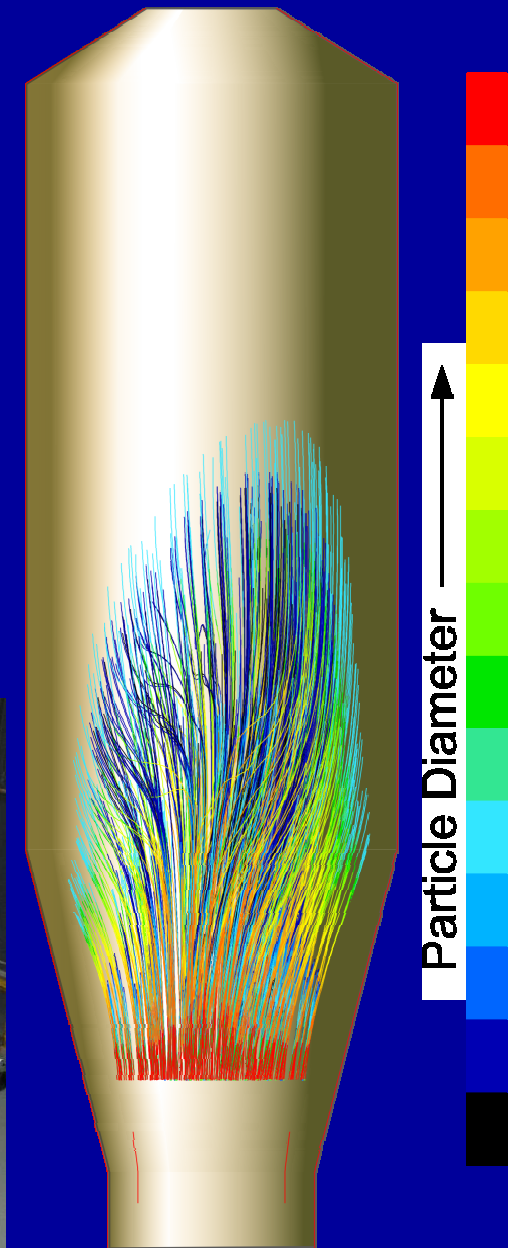
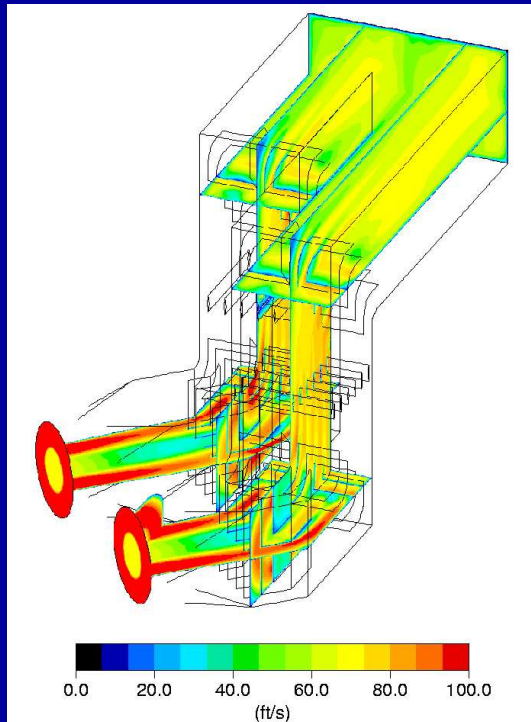
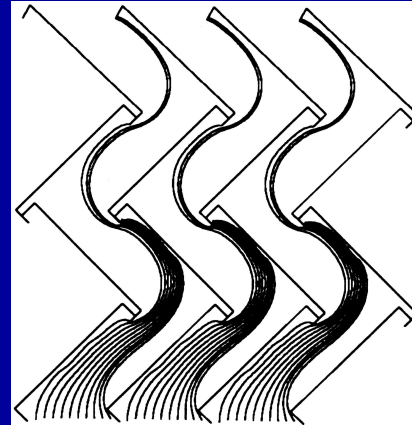

Outline

- ❖ Introduction
- ❖ Flow Modeling Methods
- ❖ Application to APC Equipment
- ❖ **Other Applications**
- ❖ Conclusions
- ❖ Questions

Power Industry

- ❖ Virtually every component of a power plant can be modeled that involves flow (air, gas, liquid, steam, particulate), heat transfer, combustion, or chemical reaction

Performance

- Heat Rate
- Capacity
- Pressure Loss
- Combustion
- Instrumentation

Environmental

- Particulate Capture
- NO_x
- SO_x
- CEMs

Maintenance

- Fouling
- Pluggage
- Erosion
- Corrosion
- Vibration



Power Industry

- ❖ Fans
- ❖ Ducts
- ❖ Pulverizers
- ❖ Windboxes
- ❖ Furnaces
- ❖ Air Heaters
- ❖ Stacks
- ❖ Turbines
- ❖ Condensers
- ❖ HRSGs
- ❖ ...

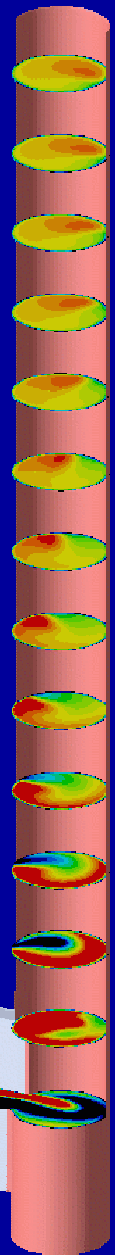
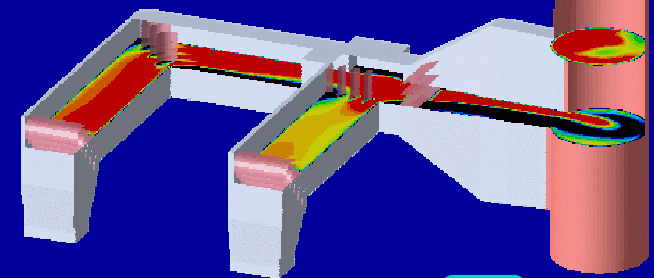
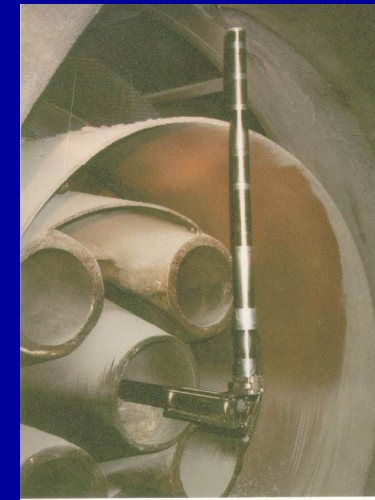
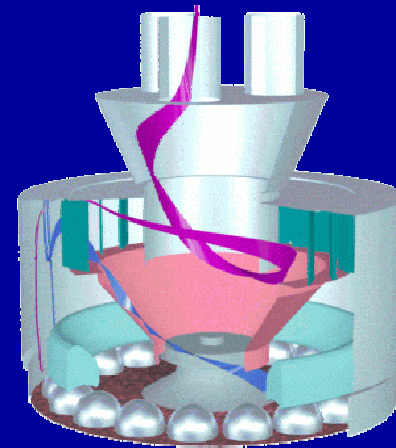
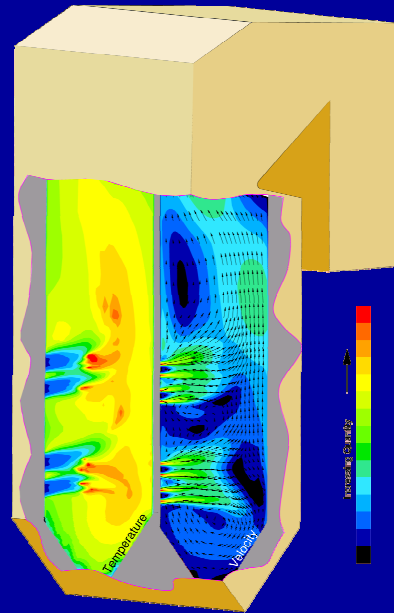

Conclusions

- ❖ Gas flow patterns have significant impact on the performance of air pollution control equipment
- ❖ Analysis and design tools include field testing and flow modeling
- ❖ CFD and physical modeling are applied to a wide range of equipment “from the fan to the stack”

Questions?

If you would like an electronic copy of this presentation, please contact Rob Mudry as follows:
rmudry@airflowsciences.com
Tel. 734-525-0300